

# NSB 110FT Red Battery®

Long float life at elevated temperatures

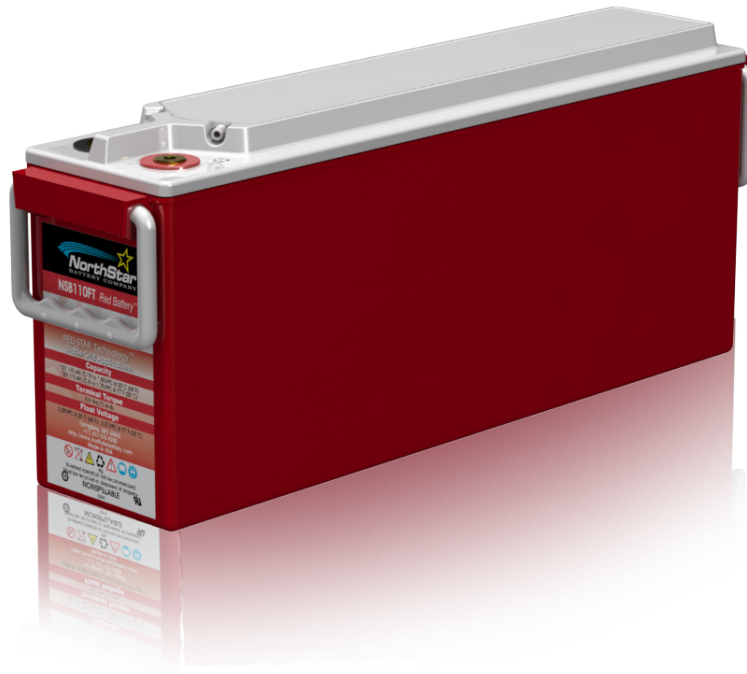

*Red Star Technology*® uses pure lead plates to deliver **exceptionally long float life even at elevated temperatures.**

- Pure lead AGM technology delivers long float life for telecom applications even at elevated temperatures
- 15 year float life at 20°C (68°F)
- EUROBAT design life definition: Long Life (12+ years)
- High energy density
- Operating temperature range: -40°C to +65°C (-40°F to 149°F)
- State-of-the-art automated manufacturing ensures consistency and reliability
- Advanced 3 stage terminal design to ensure leak-free operation - female M8 brass terminals provide maximum performance
- 2 year shelf life at 25°C (77°F)
- High modulus Polyphenylene Oxide (PPO) plastic materials designed to withstand extended elevated operating temperatures and maintain high battery compression essential for reliable operation
  - Non-halogenated, thermally sealed plastic casing
  - Flame retardant (UL 94 VO) and LOI of at least 28%
- Integral handles and front access terminals ensure ease of installation and maintenance
- Approved as non-hazardous cargo for ground, sea, and air transport - DOT 49CFR173.159(d), (i) and (ii)

Visit our website to find out more [www.northstarbattery.com](http://www.northstarbattery.com)



# NSB 110FT Red Battery®

## Nominal Technical Specifications



### Electrical

	International Standard 20°C (68°F)	North American Standard 25°C (77°F)
8 hour capacity to 1.75 VPC	107 Ah	109 Ah
10 hour capacity to 1.80 VPC	109 Ah	110 Ah
Float Voltage	2.29 +/- 0.02 VPC	2.27 +/- 0.02 VPC
Nominal Voltage	12 V	
Impedance [1kHz]	2.6 mΩ @ 25°C (77°F)	
Conductance	1,841 S	
Short Circuit Current	3,800 A	

### Dimensions

Height	227 mm (8.9 in)	Weight	39 kg (86 lbs)
Width	125 mm (4.9 in)	Terminal	Female M8 x 1.25
Depth	560 mm (22.0 in)	Terminal Torque	8.0 Nm (71 in-lbs)

### Ah Capacity Ratings @ 25°C (77°F)

Capacity Discharge / hours	1	2	4	8	10
Capacity @ 25°C / Ah	85	94	102	109	110
End of Discharge / VPC	1.70	1.75	1.75	1.75	1.80

### Drawings

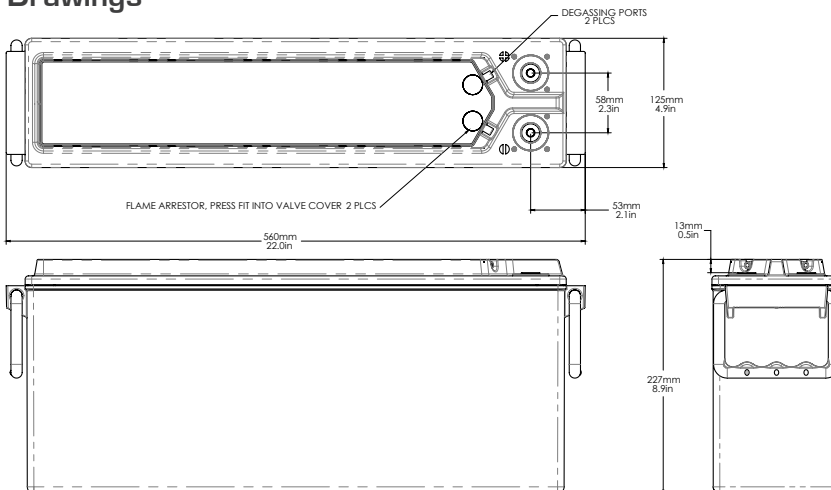

All NorthStar batteries are compliant with: Telcordia SR4228; IEC 60896; Bellcore GR-63-Core, Issue 1; British, German, and Russian telecom standards; UL approved. NorthStar is registered to ISO 9001 and ISO 14001.

#### NorthStar Americas

NorthStar Battery Company LLC  
4000 Continental Way  
Springfield, MD, 65803,  
United States of America  
info@northstarbattery.com  
Tel: +1 417 575 8200  
Fax: +1 417 575 8250

#### NorthStar Europe

SiteTel Sweden AB  
Staffans Väg 6-8  
SE-192 07 Sollentuna,  
Stockholm, Sweden  
europe@northstarbattery.com  
Tel: +46 8 410 102 00  
Fax: +46 8 638 06 00

#### NorthStar Middle East, Africa

SiteTel Sweden AB JTL Branch  
Office 702, Saba 1 Tower  
Jumeirah Lake Towers, Dubai  
United Arab Emirates  
mea@northstarbattery.com  
Tel: +971 4 423 8060  
Fax: +971 4 423 8061

#### NorthStar Asia-Pacific

NS Asia Pacific Sdn. Bhd.  
Level 20, Menara Standard Chartered  
30 Jalan Sultan Ismail, 50250  
Kuala Lumpur, Malaysia  
asia@northstarsitetel.com  
Tel: +60 3 2117 5354

[www.northstarbattery.com](http://www.northstarbattery.com)

