

Deka®

unigy®

12AVR-125L 12AVR-125LLP

FEATURES

- Pure lead positive grids
- Front access terminals
- Absorbed glass mat separators
- Tank formed plates
- Flame retardant polypropylene – UL94, V-0 28% LOI jar and cover
- Low positive pressure, self-sealing safety vents with flame arrestors
- Epoxy post seals
- Design life 10 years @ 77°F (full float)



SPECIFICATIONS

Rating: 120 ah @ 8 hr rate to 1.75 vpc,
125 ah @ 10 hr rate to 1.75 vpc

Float Voltage: 13.50 v.p.b. @ 77°F (25°C)

Weight: 120 lbs. (54.4 Kg)



DISCHARGE RATE IN AMPS

Volts Per Cell (V.P.C.)	1 HR	3 HR	5 HR	8 HR	10 HR	15 HR	20 HR	24 HR
1.75	76.80	32.93	22.37	15.36	12.67	8.83	6.86	5.88
1.80	75.84	32.64	22.08	15.17	12.48	8.64	6.72	5.76
1.88	65.28	29.76	16.80	13.44	11.52	6.24	6.05	5.57
1.90	62.40	28.32	14.40	12.96	11.04	6.05	5.95	5.47

Note: Above ratings conform to IEEE-485 standards.

"POWERED FOR PERFORMANCE"®

EAST PENN manufacturing co., inc.

Lyon Station, PA 19536-0147 • Phone: 610-682-6361 • Fax: 610-682-4781

Order Department Hotline: 610-682-4231

www.eastpennunigy.com • E-mail: sales@eastpennunigy.com

E.P.M. Form No. 0961 Rev. 1/07

QUALITY SYSTEM
CERTIFIED TO
ISO 9001
ISO/TS 16949
ISO 14001



Product Code	Nominal Voltage	Ampere Hours @ 8-hour Rate	Ampere Hours @ 10-hour Rate	Length	Width	Height	Total Weight	Acid Volume
12AVR-125L	12V	120	125	16.82 in. 427.2 mm	6.97 in. 177.0 mm	10.10 in. 256.5 mm	120lbs. 54.4 kg	2 gal. 7.57 L
12AVR-125LLP	12V	120	125	17.90 in. 454.7 mm	6.97 in. 177.0 mm	9.36 in. 237.7 mm	120lbs. 54.4 kg	2 gal. 7.57 L

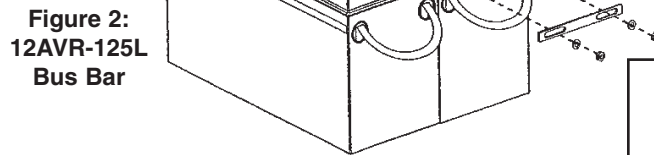
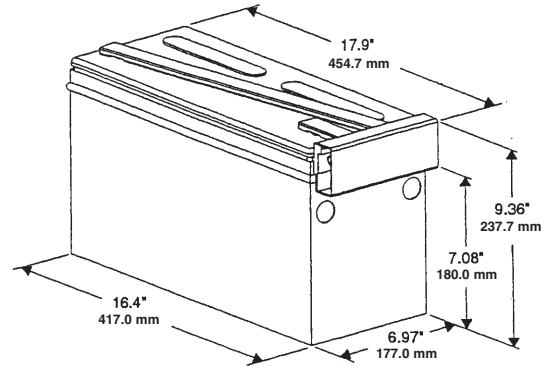
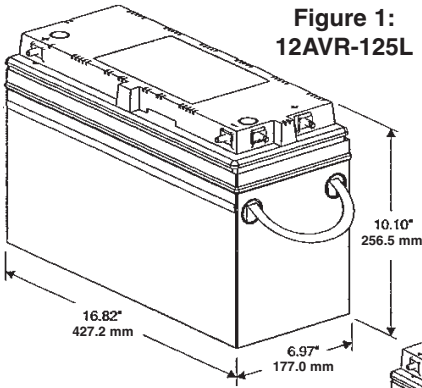

Figure 4: 12AVR-125LLP

